

BOSCH

Invented for life

WZ16 Integrated Day/Night High-res Bullet Camera



- ▶ SuperHAD 1/3 in CCD, 520 TVL
- ▶ 18 m (59 ft) night vision in zero lux
- ▶ Mechanical lens filter for 24/7 performance
- ▶ 3.8 to 9.5 mm varifocal lens
- ▶ Compact, all-weather housing

The WZ16 provides reliable day and night surveillance in a compact, water resistant design that integrates 18 infrared LEDs for 18 m (59 ft) of IR-cut filtered night vision.

Incorporating a SuperHAD 1/3 in CCD, the WZ16 delivers 520 TVL color imaging during day and 18 m (59 ft) of active-infrared night vision under zero lux.

The WZ16 also features a mechanical IR-cut lens filter for accurate daytime color and exceptional performance under infrared. Mechanical filter technology minimizes IR bleed and prevents focus shift from daytime to night-time modes.

The WZ16 uses 18 photocell-controlled infrared LEDs to deliver up to 18 m (59 ft) of night vision for effective 24/7 performance. Photocell-controlled LEDs ensure accurate on/off switching and help increase energy efficiency.

The WZ16 includes a versatile mounting bracket suitable for walls, surfaces and ceilings, as well as a sun hood. Constructed of extruded aluminum, the WZ16 is compact and discreet, featuring an anodized silver finish.

The WZ16 is a quick and easy Plug-and-Play solution for 24/7 day and night surveillance.

- Warehouses
- Service stations
- Commercial
- Parking lots
- Retail
- Perimeters
- Transportation hubs
- Ports
- Residential
- Hotels and nightclubs
- Schools and colleges

Installation/Configuration Notes

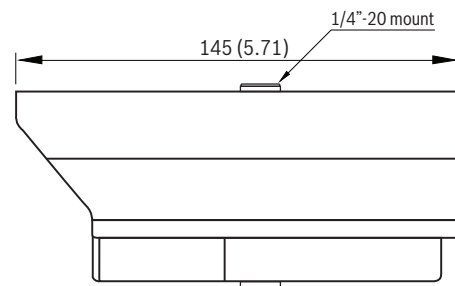

Functions

Applications

- Industrial sites
- Casinos

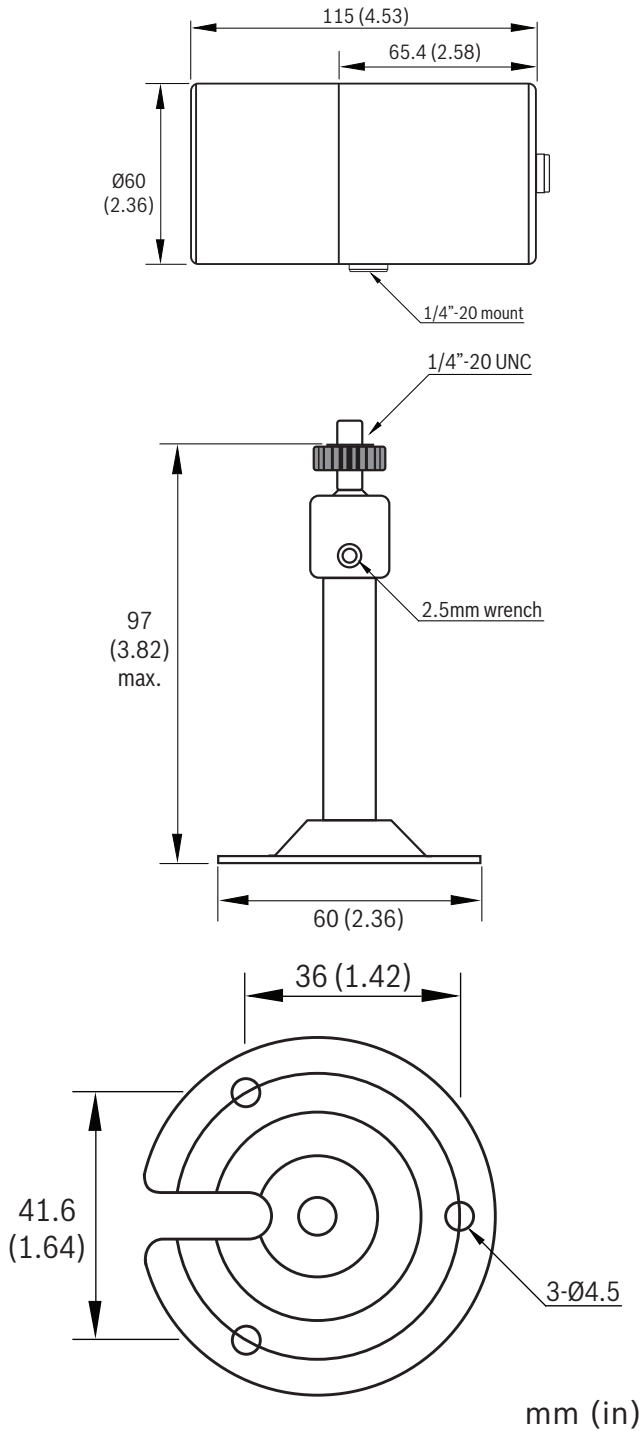

Technical Specifications

Video

Signal Processing	Digital signal processing (DSP)
CCD Camera	1/3 in SuperHAD CCD
Filter	IR-Cut, lens mounted
Resolution	High resolution 520 TVL
Effective Pixels (H x V)	PAL: 752 x 582, NTSC: 768 x 494
Night-Time Sensitivity	0 lux (infrared on)
Electronics Iris	1/50 to 1/100,000 s (PAL), 1/60 to 1/100,000 s (NTSC)

Output Signal 1 VPP composite video, 75 ohm

S/N Ratio Greater than 48 dB

Gamma 0.45

Lens Varifocal 3.8 to 9.5 mm, DC auto-iris

LEDs Infrared array, photocell-controlled

Wavelength 850 nm

Number of LEDs 18

Electrical

Voltage 12 to 24 VDC or VAC

Power Draw 6 W Max.

Power Supply Not included

Mechanical

Construction Robust aluminum extrusion

Finish Anodized silver

Sunshield Included as standard

Bracket Pan-tilt bracket included as standard

Weight 0.56 kg (1.2 lb)

Dimensions $\varnothing 60 \times 145$ (L) mm (2.4 x 5.7 in)

Environmental

Operation Temperature Range -30 °C to +55 °C (-22 °F to +131 °F)

Environment IP67 compliant

Ordering Information**WZ16NV408-0 IDN High-res Bullet Camera WZ16NV408-0**

IDN bullet cam, 520TVL, SuperHAD, color switching to bw, lens filter, 18LEDs, silver, NTSC, 3.8 to 9.5 mm lens, PSU separate

WZ16PV408-0 IDN High-res Bullet Camera WZ16PV408-0

IDN bullet cam, 520TVL, SuperHAD, color switching to bw, lens filter, 18LEDs, silver, PAL, 3.8 to 9.5 mm lens, PSU separate

Accessories**UPA-1220-60 Power Supply UPA-1220-60**

120VAC, 60Hz, 12VDC, 1A Out, regulated

UPA-1220-50 Power Supply UPA-1220-50

220VAC, 50Hz, 12VDC, 1A Out, regulated

Americas:

Bosch Security Systems, Inc.
130 Perinton Parkway
Fairport, New York, 14450, USA
Phone: +1 800 289 0096
Fax: +1 585 223 9180
security.sales@us.bosch.com
www.boschsecurity.us

Europe, Middle East, Africa:

Bosch Security Systems B.V.
P.O. Box 80002
5600 JB Eindhoven, The Netherlands
Phone: +31 40 2577 284
Fax: +31 40 2577 330
emea.securitysystems@bosch.com
www.boschsecurity.com

Asia-Pacific:

Robert Bosch (SEA) Pte Ltd, Security Systems
11 Bishan Street 21
Singapore 573943
Phone: +65 6571 2600
Fax: +65 6571 2698
apr.securitysystems@bosch.com
www.boschsecurity.com

Represented by